

PROTEC ES200CRH

CD Curved Door Portfolio Sliding doors in any imaginable radius

Automatic Sliding Door Opener

ES 200

ES 200 CRH

Germany Dunkermotoren Motor

Intelligent technology

Precise control

Sensitive operation

Flexible in every
aspect



PROTEC
AUTOMATION

PROTEC 120KG ES200CRH Automatic Door Operators System Controller Unit Curved Door Opener With Aluminum Alloy

A proven concept. Our sliding door system is the core component of our automatic door drives. Starting with this system, we can provide a wide range of doors based on the same components, which are adapted to the respective requirements.

curved convex sliding doors. Whether you're looking to create a grand entrance, a minimalistic doorway or a captivating focal point, these doors will adapt effortlessly to your unique vision. Curving inside or out, at virtually any angle, is their speciality. Their sleek design and silent operation make them the perfect choice for architects around the world.

High-Quality Design: The Protec ES200CRH Automatic Door Operators System Controller Unit features a modern design style, ensuring a sleek and sophisticated look for your villa's entrance. Its aluminum alloy construction guarantees durability and resistance to corrosion.

Efficient Operation: This electric door system is designed for efficient operation, making it ideal for villas with curved gates. The system is easy to install and provides smooth door opening and closing.

Advanced Features: The ES200CRH comes with a program key switch, allowing for customizable settings and easy operation. This feature is especially useful for users who value convenience and flexibility.

User-Friendly Experience: The ES200CRH is designed to provide a seamless user experience, making it easy for users, including you, to operate and maintain the system.

PRODUCT PARAMETERS

Max. door weight (single)	1×120KG
Max. door weight (double)	2×100KG
Door width	600~2500mm(adjustable)
Arc radius	>/1000mm
Orbit radius	Customized
Power input	AC220V(±10%), 50-60Hz
Motor type	24V 65W BLDC
Installation mode	WALL
Running noise	<60dB
Electric lock output	0-60S(adjustable)
Opening and closing time	0~20S
Operating temperature	-20~+50°C

PRODUCT PARAMETERS

- Microcomputer intelligent control and advanced mechanic
- Automatically adjust the operation status of the door leaf, and manually adjust it if necessary
- Smooth opening and closing, low noise
- Brushless motor, long service life
- Dual door interlock and electronic lock functions, support -ing multiple access control systems
- Dual purpose light and heavy, with large bearing capacity.
- Easy to install.

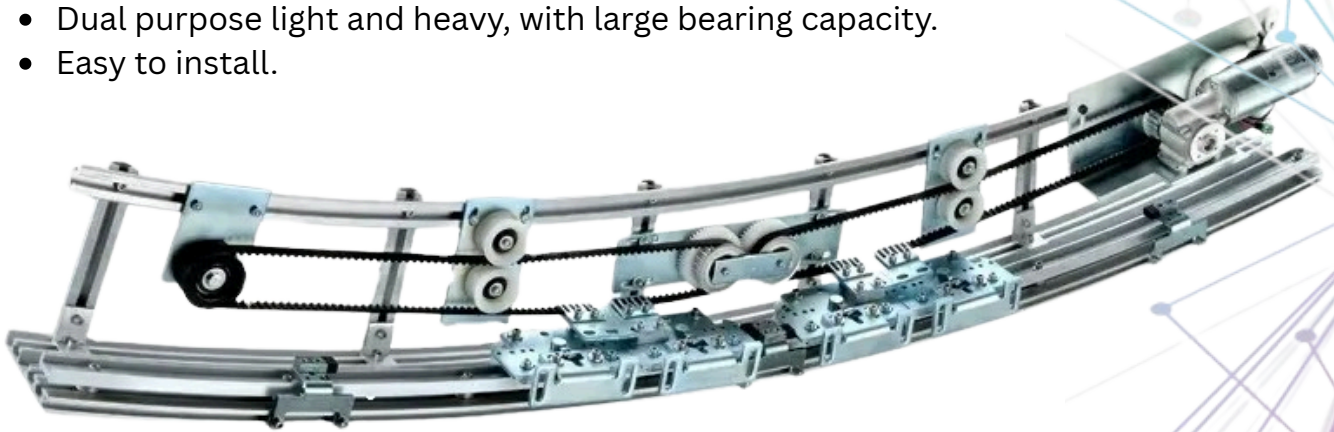

Please contact type agents for more information